

Load Labels in 10 Steps

1. Turn on the scanner.
2. Press the latch buttons and open the supply cover.

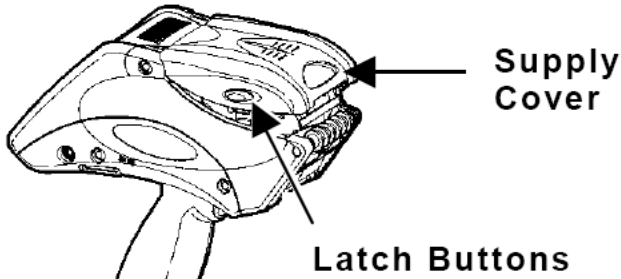

3. Peel and discard the first four labels from the backing paper.
4. Place the label roll in the supply holder so the labels feed from the bottom.

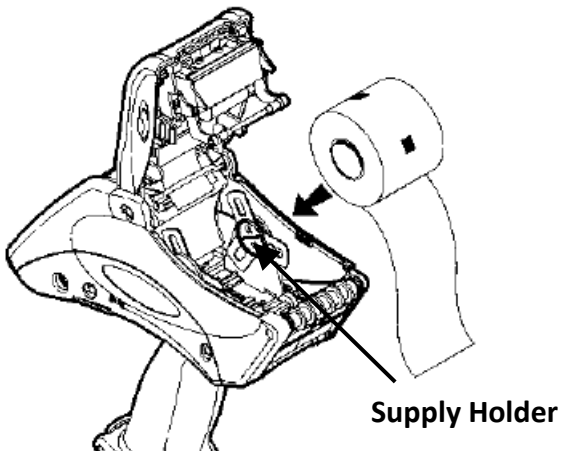

5. Hold the printer upright and gently press down on the label deflector. (It may be stiff.)

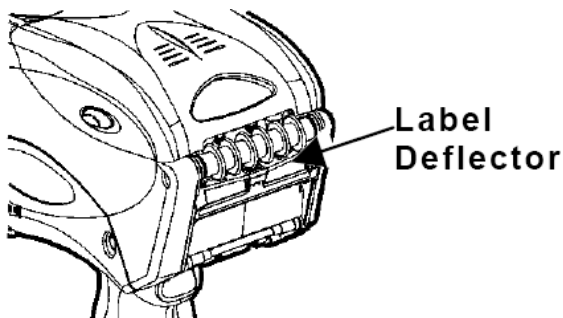

6. Feed the blank backing paper **UNDER** the applicator roller, **OVER** the metal (peel) bar and **UNDER** the label deflector.

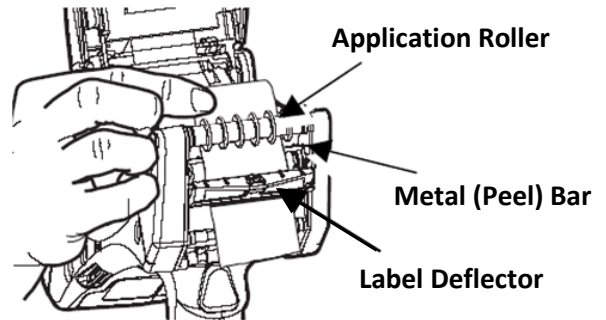

7. Push the label deflector up until it snaps into place.
8. Close the supply cover.
9. Pull the backing paper **over** the guide roller and down to the pinch and feed rollers.
10. Hold the backing paper edge between the feed and pinch rollers, then select the **Hot Key** button and press **Paper Feed**. The scanner should print a label that reads **!! PAPER FEED !!**.

